

## Li/MnO<sub>2</sub> Primary System

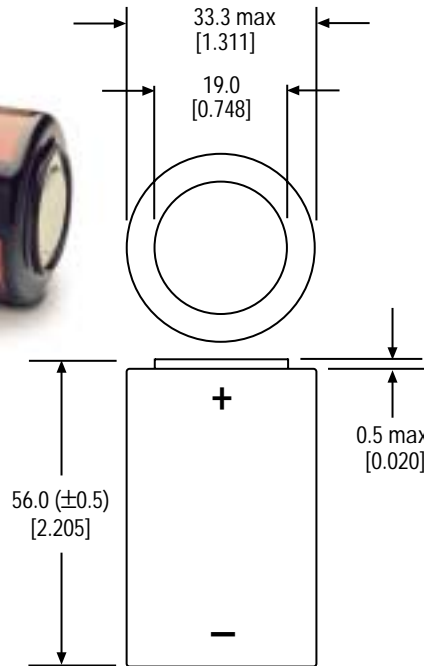

Dimensions  
in mm  
(inches)

### U3356H

System:	Lithium/Manganese Dioxide
Part No:	U10002
Nominal Voltage:	3.0 Volts
Capacity (C):	10 AHrs @ 200 mA to 2V @ 23°C
Max. Discharge:	3.0 Amps Continuous
Weight:	108 grams max.
Oper. Temp. Range:	-40° to 72°C
Storage Temp. Range:	-55° to 80°C
Volume:	48 cm <sup>3</sup>
Terminals:	Flat End Caps; Tabs Available
Housing:	Stainless Steel with Laser Welded Hermetic Seal and Insulating Label
Notes:	High pulse currents and higher continuous currents can be achieved. Contact Ultralife Batteries, Inc. for details.

